

GR3/GR4-SERIES

Guide Rails

Liberty Pumps®

A Family and Employee Owned Company

**For use with LSS-Series
and LSV-Series pumps**

Features

- Class 30 heavy cast iron construction
- Sized for 2" rail pipes (not included)
- Durable nitrile sealing grommet
- Upper stainless steel rail support and mid guide rail support bracket included
- Powder coated for corrosion resistance
- Available in 3" and 4" ANSI®
- Maximum pump weight 750 lbs (340 kg)



Mid Support Bracket

Models

MODEL	ANSI SIZE	WEIGHT IN LBS	SERIES
GR3-ANSI	3"	137	LSS
GR4-ANSI	4"	150	LSV

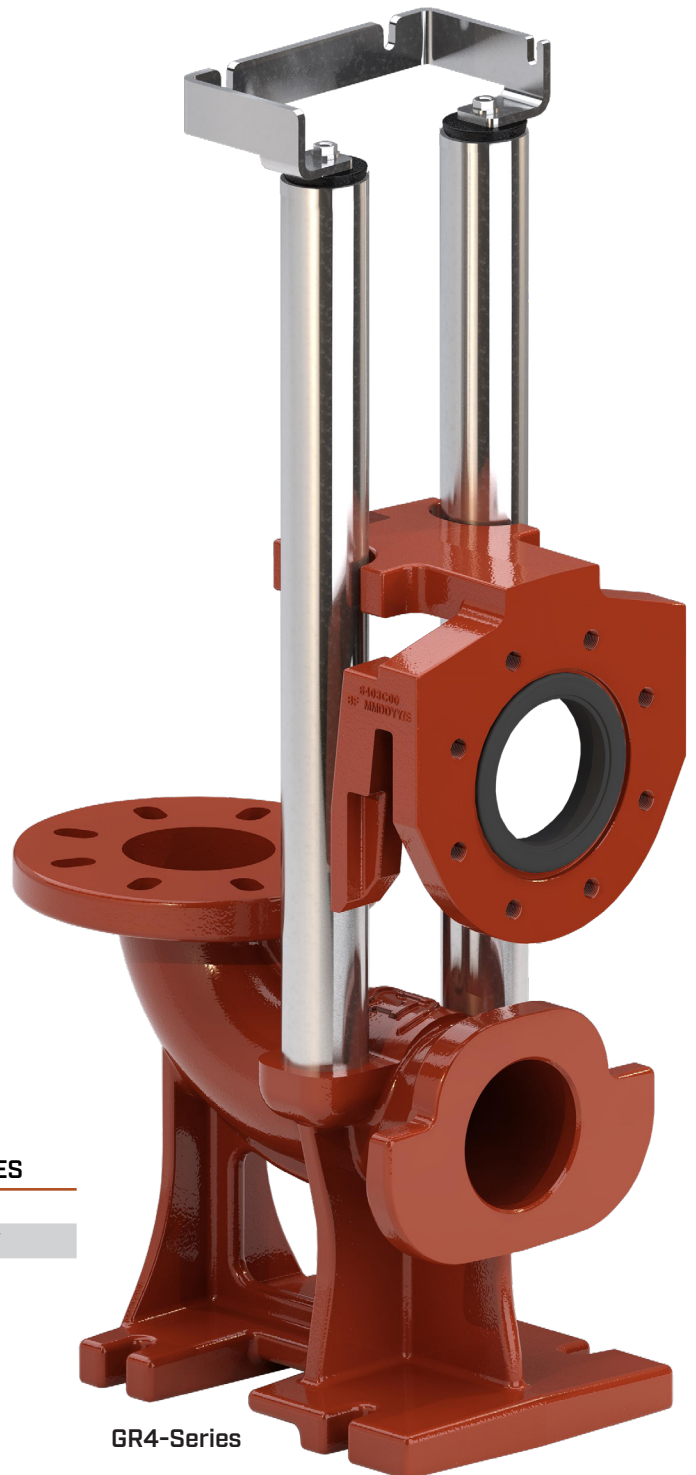

GR4-Series



innovate. evolve.

GR3/GR4-Series

Material

Class 30 gray cast iron

Seal

Heavy duty nitrile

Rail Size

2" (Not included)

Discharge

All flanges are machined to ANSI 150 lb specifications
(See chart for model-specific information)

Maximum Pump Weight

750 lbs

Upper and Mid Guide Rail Support

Stainless steel

Claw Attachment Bolts

5/8" - 11 x 1.5" Stainless steel

Dimensional Data

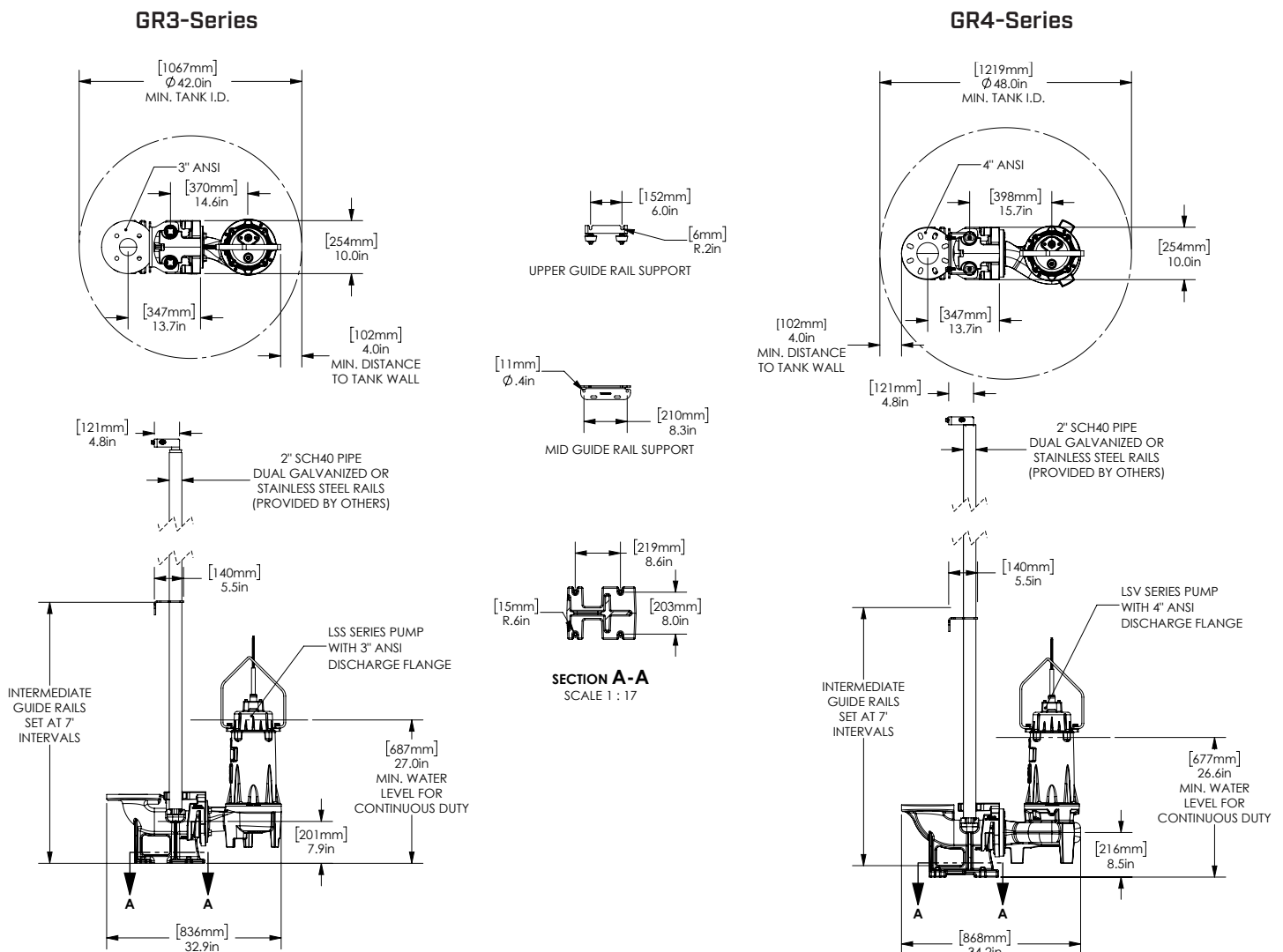

Specifications subject to change without notice.

Copyright © Liberty Pumps, Inc. 2024 All rights reserved. LLIT006793-R02/24

Liberty Pumps - 7000 Apple Tree Avenue - Bergen, New York 14416
Phone 800-543-2550 - Fax 585-494-1839 - www.LibertyPumps.com